



# MBRB20100CT thru MBRB20200CT

## 20.0A Schottky Barrier Rectifiers

Rectifier Reverse Voltage 100 to 200V

### TO-263

#### Features

- High frequency operation
- High purity, high temperature epoxy encapsulation for enhanced mechanical strength and moisture resistance
- Guard ring for enhanced ruggedness and long term reliability
- Solder dip 260 °C max. 8 s, per JESD 22-B106

#### Mechanical Data

- **Package:** TO-220AB  
Molding compound meets UL 94 V-0 flammability rating, RoHS-compliant
- **Terminals:** Tin plated leads, solderable per J-STD-002 and JESD22-B102
- **Polarity:** As marked

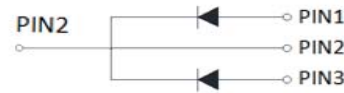
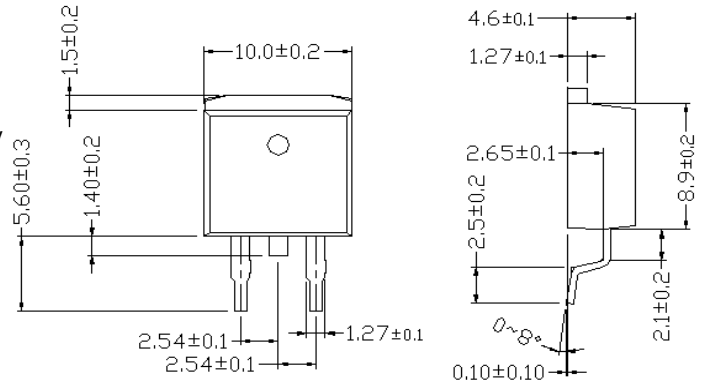

Dimensions in millimeters ( 1mm =0.0394" )

#### ■Maximum Ratings (Ta=25°C Unless otherwise specified)

PARAMETER	SYMBOL	UNIT	MBRB20100CT	MBRB20150CT	MBRB20200CT
Device marking code			MBRB20100CT	MBRB20150CT	MBRB20200CT
Repetitive Peak Reverse Voltage	VRRM	V	100	150	200
Average Rectified Output Current @60Hz sine wave, R-load, Ta=25°C	IO	A	20		
Surge(Non-repetitive)Forward Current @60Hz half sine-wave, 1 cycle, Ta=25°C	IFSM	A	150		
Current Squared Time @1ms≤t<8.3ms Tj=25°C,	I <sup>2</sup> t	A <sup>2</sup> s	94		
Storage Temperature	Tstg	°C	-55 ~ +175		
Junction Temperature	Tj	°C	-55 ~ +150		

#### ■Electrical Characteristics (Ta=25°C Unless otherwise specified)

PARAMETER	SYMBOL	UNIT	TEST CONDITIONS	MBRB20100CT	MBRB20150CT	MBRB20200CT
Maximum instantaneous forward voltage drop per diode	VFM	V	IFM=10.0A	0.88	0.92	0.95
Maximum DC reverse current at rated DC blocking voltage per diode	I <sub>RRM1</sub>	mA	V <sub>RM</sub> =V <sub>RRM</sub> Ta=25°C	0.15	0.1	
	I <sub>RRM2</sub>		V <sub>RM</sub> =V <sub>RRM</sub> Ta=125°C	20		
Thermal Resistance	R <sub>θJ-C</sub>	°C/W	Between junction and case	2.0		

# Rating and Characteristic Curves ( $T_A=25^\circ\text{C}$ Unless otherwise noted )

## MBRB20100CT thru MBRB20200CT

FIG1:  $I_o$  -  $T_c$  Curve

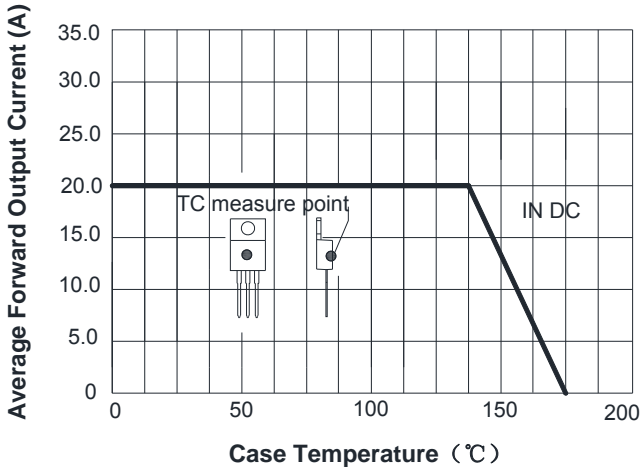

FIG2: Surge Forward Current Capability

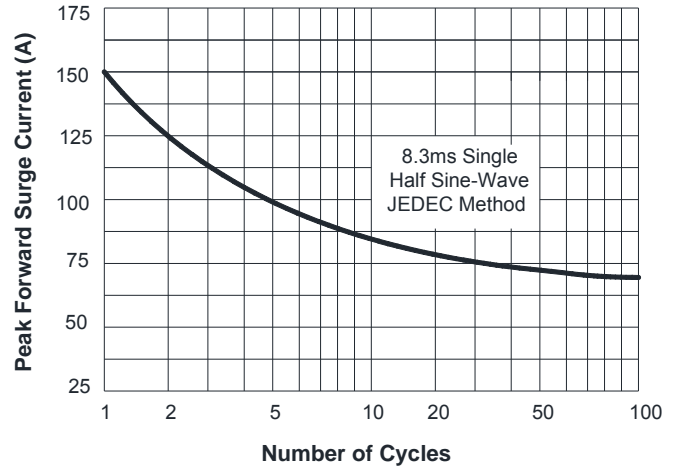

FIG3: Forward Voltage

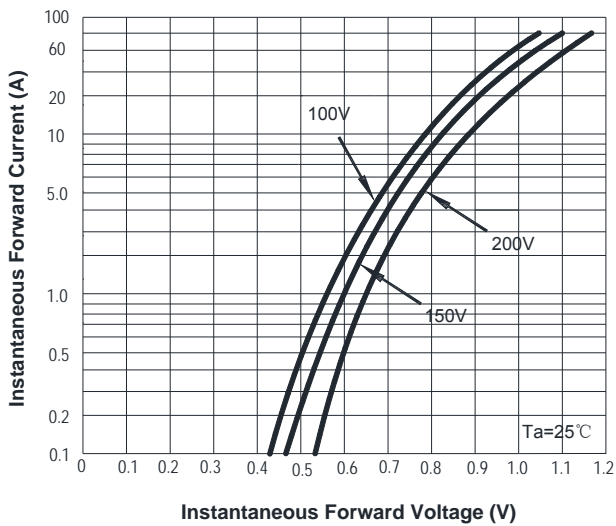

FIG4: Instantaneous Reverse Characteristics

