



# 4GBJ4005 thru 4GBJ410

## 4.0 A Single-Phase Silicon Bridge Rectifier Rectifier Reverse Voltage 50 to 1000V

### Features

- Ideal for printed circuit board mounting
- This series is UL listed under the Recognized Component Index, file number E142814
- The plastic material used carries Underwriters Laboratory flammability recognition 94V-0
- Built-in printed circuit board stand-offs
- High case dielectric strength
- High temperature soldering guaranteed 260°C /5 seconds at 5 lbs (2.3kg) tension

### Mechanical Data

Case: Reliable low cost construction utilizing molded plastic technique

Terminals: Plated leads solderable per MIL-STD-202, Method 208

Mounting Position: Any

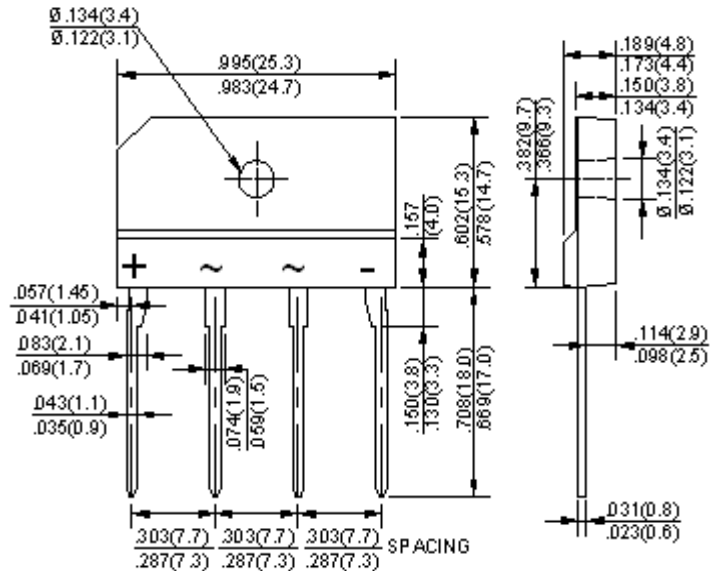

Dimensions in inches and (millimeters)

### Maximum Ratings & Thermal Characteristics

Rating at 25°C ambient temperature unless otherwise specified, Resistive or Inductive load, 60 Hz.  
For Capacitive load derate current by 20%.

CHARACTERISTICS	SYMBOL	4GBJ 4005	4GBJ 401	4GBJ 402	4GBJ 404	4GBJ 406	4GBJ 408	4GBJ 410	UNIT
Maximum Recurrent Peak Reverse Voltage	V <sub>RRM</sub>	50	100	200	400	600	800	1000	V
Maximum RMS Voltage	V <sub>RMS</sub>	30	70	140	280	420	560	700	V
Maximum DC Blocking Voltage	V <sub>DC</sub>	50	100	200	400	600	800	1000	V
Maximum Average Forward (with heatsink Note 2)	I <sub(av)< sub=""></sub(av)<>	4.0							A
Peak Forward Surge Current 8.3ms Single Half Sine-Wave Super Imposed on Rated Load (JEDEC Method)	I <sub>FSM</sub>	130							A
Maximum Forward Voltage at 4.0A DC	V <sub>F</sub>	1.1							V
Maximum DC Reverse Current @ T <sub>J</sub> =25°C at Rated DC Blocking Voltage @ T <sub>J</sub> =125°C	I <sub>R</sub>	10 500							uA
Typical Thermal Resistance (Note2)	R <sub>θJC</sub>	2.3							°C/W
Operating Temperature Range	T <sub>J</sub>	-55 to +150							°C
Storage Temperature Range	T <sub>STG</sub>	-55 to +150							°C

NOTES: 1. Measured at 1.0MHz and applied reverse voltage of 4.0V DC.

2. Device mounted on 300mm\*300mm\*1.6mm cu plate heatsink.

**Rating and Characteristic Curves** (  $T_A=25^{\circ}\text{C}$  Unless otherwise noted )  
**4GBJ4005 thru 4GBJ410**

FIG.1-FORWARD CURRENT DERATING CURVE

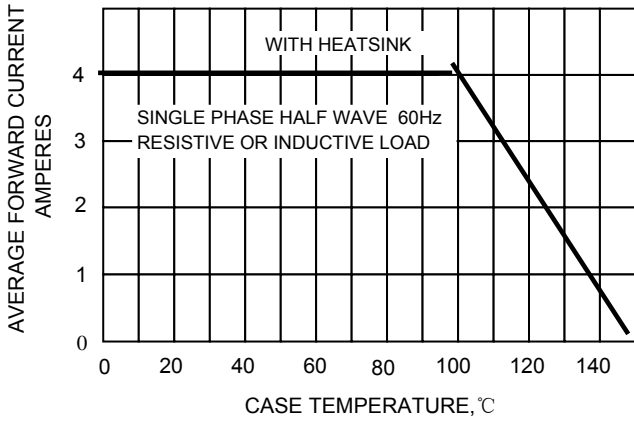

FIG.2-MAXMUN NON-REPETITIVE SURGE CURRENT

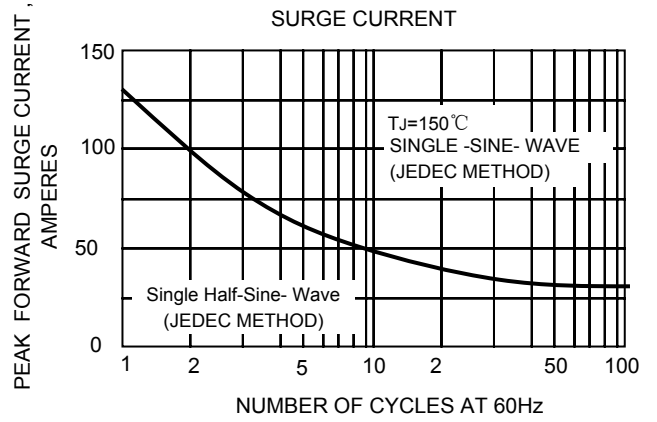

FIG.3-TYPICAL JUNCTION CAPACITANCE

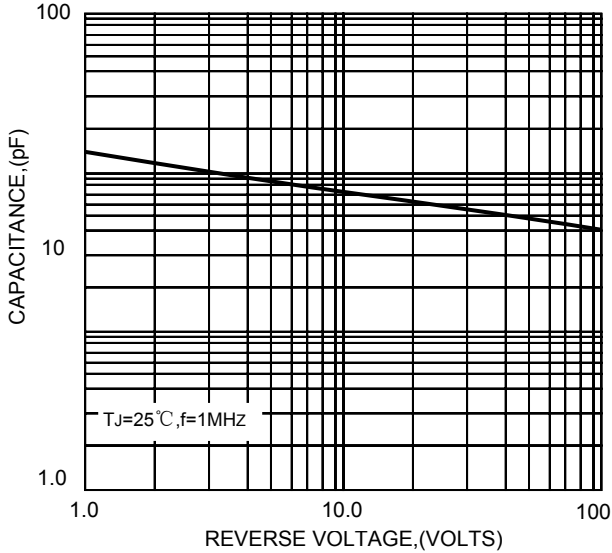

FIG.4-TYPICAL FORWARD CHARACTERISTICS

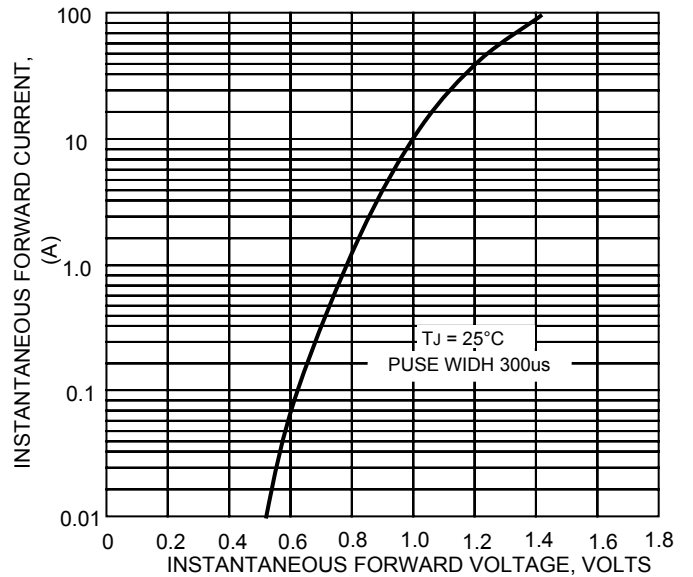

FIG.5-TYPICAL REVERSE

